

SECTION B-B

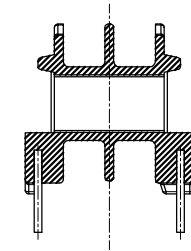

SECTION A-A

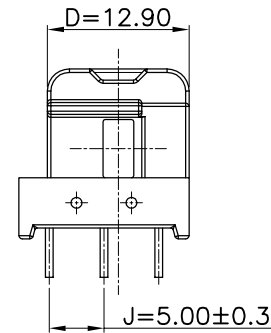
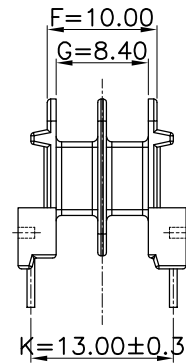
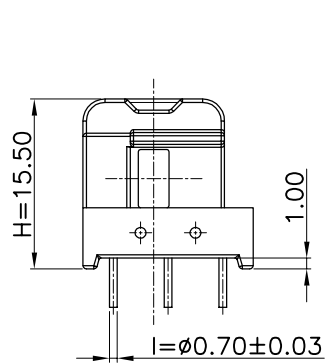
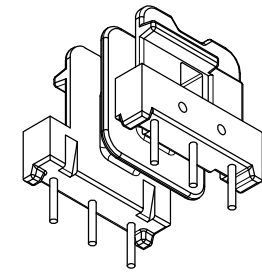
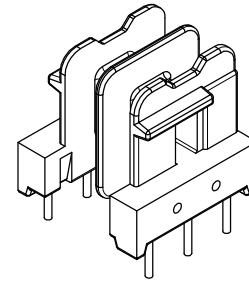
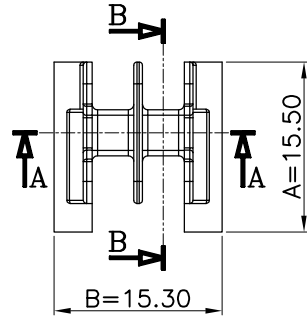
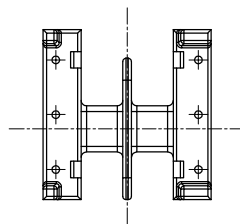

▲							
▲							
▲							
▲							
MARK	REVISION NOTE			DATE	DRAWN	CHECKED	APPROVED
DRAWN	CHECKED	APPROVED	MATERIAL : PHENOL	UL REC. : UL94V-0	THIRD ANGLE PROJ.	SCALE : 1/1	
S H, Kim	G Y, Kim	C, Park		DATE : 2011.05.20	TOLERANCE : ±0.2 (Unless otherwise specified)	UNIT : m/m	
주식회사 대흥보빈 DAE HEUNG BOBBIN CO., LTD			TITLE UU 11*15 (6P) "H"		DWG NO DH-110623-1023-00		